

# DATA SHEET

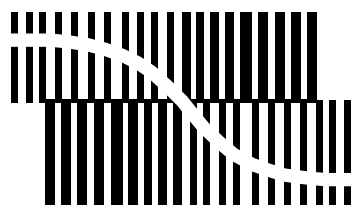

BITSTREAM CONVERSION

## **UDA1344TS**

Low-voltage low-power stereo  
audio CODEC with DSP features

Product specification  
Supersedes data of 2001 Mar 27  
File under Integrated Circuits, IC01

2001 Jun 29

# Low-voltage low-power stereo audio CODEC with DSP features

## UDA1344TS

### FEATURES

#### General

- Low power consumption
- 3.0 V power supply
- System clock of  $256f_s$ ,  $384f_s$  and  $512f_s$
- Supports sampling frequencies from 8 to 55 kHz
- Non-inverting ADC plus integrated high-pass filter to cancel DC offset
- ADC supports 2 V (RMS) input signals
- Overload detector for easy record level control
- Separate power control for ADC and DAC
- Integrated digital interpolation filter plus non-inverting DAC
- Functions controllable either via L3 microcontroller interface or via static pins
- UDA1344TS is pin and function compatible with UDA1340M
- Small package size (SSOP28)
- Easy application.

#### Multiple format input interface

- I<sup>2</sup>S-bus, MSB-justified or LSB-justified 16, 18 and 20 bits format compatible
- Three combined data formats with MSB-justified output and LSB-justified 16, 18 and 20 bits input
- $1f_s$  input and output format data rate.

#### DAC digital sound processing

The sound processing features of the UDA1344TS can be used in the L3 mode only:

- Digital tone control, bass boost and treble
- Digital dB-linear volume control (low microcontroller load) via L3 microcontroller
- Digital de-emphasis for 32, 44.1 and 48 kHz
- Soft mute.

### ORDERING INFORMATION

TYPE NUMBER	PACKAGE		
	NAME	DESCRIPTION	VERSION
UDA1344TS	SSOP28	plastic shrink small outline package; 28 leads; body width 5.3 mm	SOT341-1

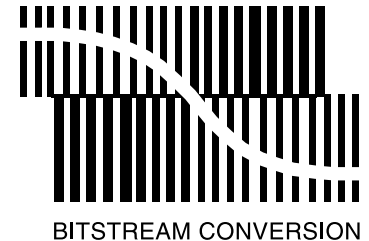

#### Advanced audio configuration

- Stereo single-ended input configuration
- Stereo line output (under microcontroller volume control), no post filter required
- High linearity, dynamic range and low distortion.

#### GENERAL DESCRIPTION

The UDA1344TS is a single-chip stereo Analog-to-Digital Converter (ADC) and Digital-to-Analog Converter (DAC) with signal processing features employing bitstream conversion techniques. The low power consumption and low voltage requirements make the device eminently suitable for use in low-voltage low-power portable digital audio equipment which incorporates recording and playback functions.

The UDA1344TS supports the I<sup>2</sup>S-bus data format with word lengths of up to 20 bits, the MSB-justified data format with word lengths of up to 20 bits and the LSB-justified data format with word lengths of 16, 18 and 20 bits. The UDA1344TS also supports three combined data formats with MSB-justified data output and LSB-justified 16, 18 and 20 bits data input.

The UDA1344TS can be controlled either via static pins or via the L3 interface. In the L3 mode the UDA1344TS has special Digital Sound Processing (DSP) features in playback mode such as de-emphasis, volume control, bass boost, treble and soft mute.

# Low-voltage low-power stereo audio CODEC with DSP features

UDA1344TS

**QUICK REFERENCE DATA**

SYMBOL	PARAMETER	CONDITIONS	MIN.	TYP.	MAX.	UNIT
<b>Supplies</b>						
$V_{DDA(ADC)}$	ADC analog supply voltage		2.7	3.0	3.6	V
$V_{DDA(DAC)}$	DAC analog supply voltage		2.7	3.0	3.6	V
$V_{DDO}$	operational amplifier supply voltage		2.7	3.0	3.6	V
$V_{DDD}$	digital supply voltage		2.7	3.0	3.6	V
$I_{DDA(ADC)}$	ADC analog supply current	operating	–	9.0	11.0	mA
		ADC power-down	–	3.5	5.0	mA
$I_{DDA(DAC)}$	DAC analog supply current	operating	–	4.0	6.0	mA
		DAC power-down	–	25	75	$\mu$ A
$I_{DDO}$	operational amplifier supply current	operating	–	4.0	6.0	mA
		DAC power-down	–	250	350	$\mu$ A
$I_{DDD}$	digital supply current	operating	–	6.0	9.0	mA
		DAC power-down	–	2.5	4.0	mA
		ADC power-down	–	3.5	5.0	mA
$T_{amb}$	ambient temperature		–40	–	+85	$^{\circ}$ C
<b>Analog-to-digital converter</b>						
$V_{i(rms)}$	input voltage (RMS value)	notes 1 and 2	–	1.0	–	V
(THD + N)/S	total harmonic distortion-plus-noise to signal ratio	at 0 dB	–	–85	–80	dB
		at –60 dB; A-weighted	–	–35	–30	dB
S/N	signal-to-noise ratio	$V_i = 0$ V; A-weighted	–	95	–	dB
$\alpha_{cs}$	channel separation		–	100	–	dB
<b>Digital-to-analog converter</b>						
$V_{o(rms)}$	output voltage (RMS value)	notes 3 and 4	–	900	–	mV
(THD + N)/S	total harmonic distortion-plus-noise to signal ratio	at 0 dB	–	–90	–85	dB
		at –60 dB; A-weighted	–	–37	–	dB
S/N	signal-to-noise ratio	code = 0; A-weighted	–	100	–	dB
$\alpha_{cs}$	channel separation		–	100	–	dB
<b>Power performance</b>						
$P_{ADDA}$	power consumption in record and playback mode		–	69	–	mW
$P_{DA}$	power consumption in playback mode		–	42	–	mW
$P_{AD}$	power consumption in record mode		–	37.5	–	mW
$P_{PD}$	power consumption in power-down mode		–	17	–	mW

**Notes**

1. The input voltage can be up to 2 V (RMS) when the current through the ADC input pin is limited to approximately 1 mA by using a series resistor.
2. The input voltage to the ADC is inversely proportional to the supply voltage.
3. The output voltage of the UDA1344TS differs from the output voltage of the UDA1340M.
4. The output of the DAC scales proportionally with the supply voltage.

Low-voltage low-power stereo audio CODEC with DSP features

UDA1344TS

BLOCK DIAGRAM

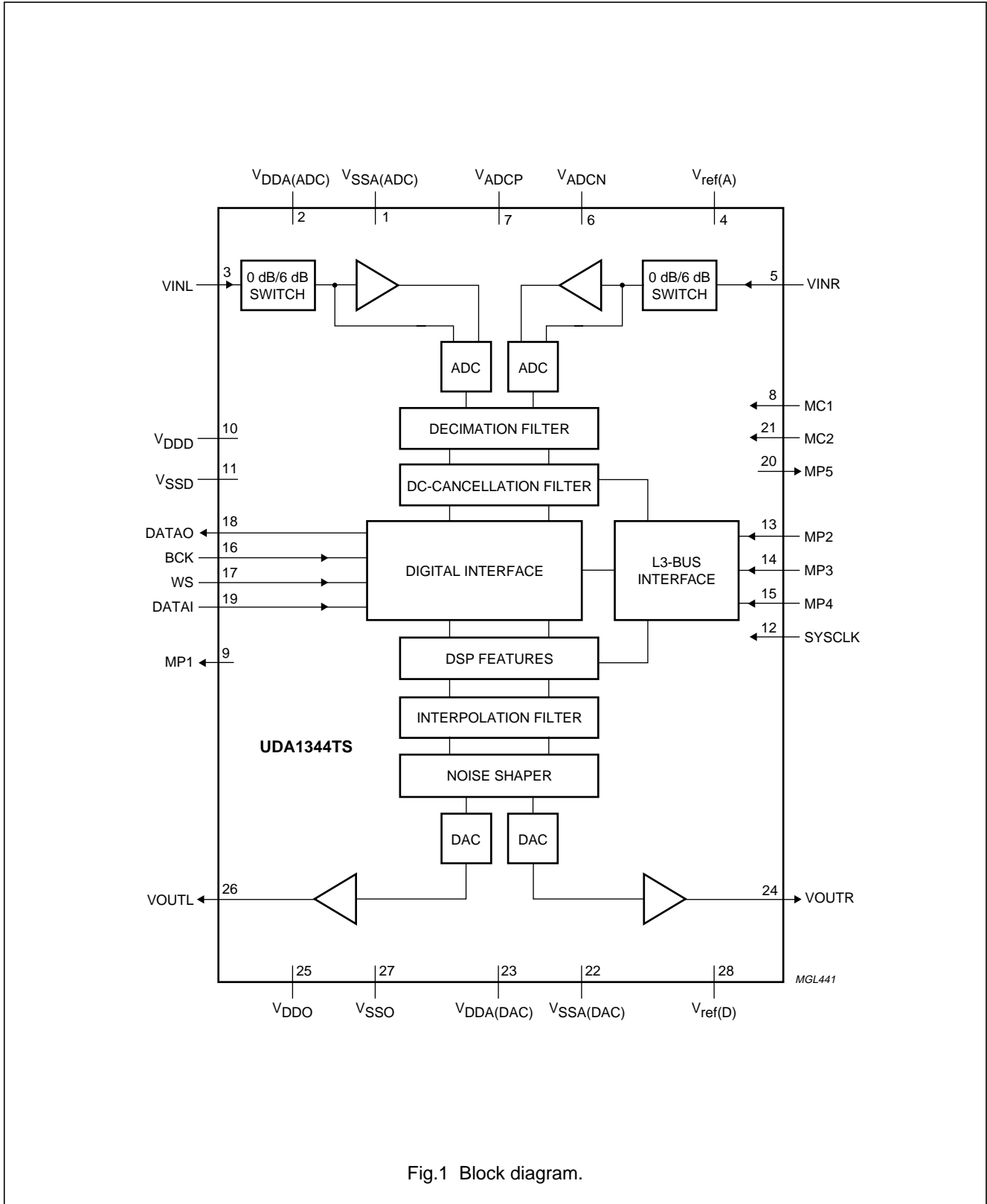

Fig.1 Block diagram.

# Low-voltage low-power stereo audio CODEC with DSP features

## UDA1344TS

### PINNING

SYMBOL	PIN	DESCRIPTION
$V_{SSA(ADC)}$	1	ADC analog ground
$V_{DDA(ADC)}$	2	ADC analog supply voltage
VINL	3	ADC input left
$V_{ref(A)}$	4	ADC reference voltage
VINR	5	ADC input right
$V_{ADCN}$	6	ADC negative reference voltage
$V_{ADCP}$	7	ADC positive reference voltage
MC1	8	mode control 1 input (pull-down)
MP1	9	multi-purpose pin 1 output
$V_{DDD}$	10	digital supply voltage
$V_{SSD}$	11	digital ground
SYSCLK	12	system clock input: 256f <sub>s</sub> , 384f <sub>s</sub> or 512f <sub>s</sub>
MP2	13	multi-purpose pin 2 input
MP3	14	multi-purpose pin 3 input
MP4	15	multi-purpose pin 4 input
BCK	16	bit clock input
WS	17	word select input
DATAO	18	data output
DATAI	19	data input
MP5	20	multi-purpose pin 5 output (pull-down)
MC2	21	mode control 2 input (pull-down)
$V_{SSA(DAC)}$	22	DAC analog ground
$V_{DDA(DAC)}$	23	DAC analog supply voltage
VOU <sub>TR</sub>	24	DAC output right
$V_{DDO}$	25	operational amplifier supply voltage
VOU <sub>TL</sub>	26	DAC output left
$V_{SSO}$	27	operational amplifier ground
$V_{ref(D)}$	28	DAC reference voltage

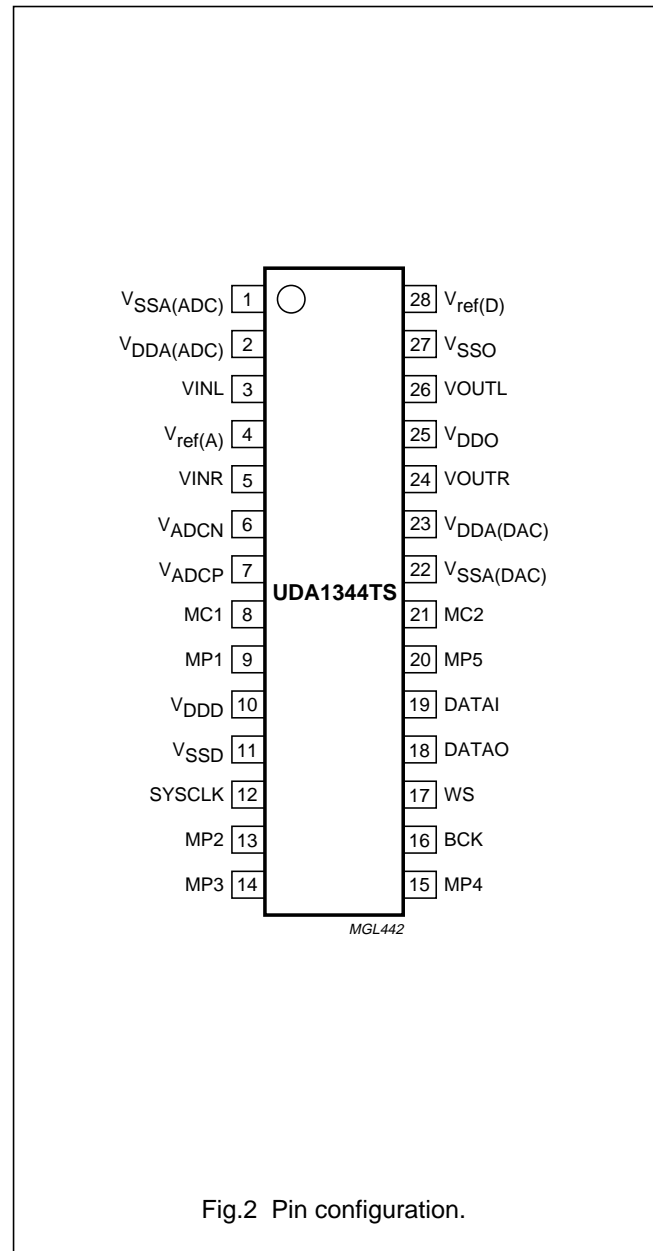

Fig.2 Pin configuration.

# Low-voltage low-power stereo audio CODEC with DSP features

## UDA1344TS

### FUNCTIONAL DESCRIPTION

The UDA1344TS accommodates slave mode only, this means that in all applications the system devices must provide the system clock. The system clock must be locked in frequency to the digital interface input signals.

The BCK clock can be up to  $128f_s$ , or in other words the BCK frequency is 128 times the Word Select (WS) frequency or less:  $f_{BCK} = < 128 \times f_{WS}$ .

#### Remarks:

1. The WS edge MUST fall on the negative edge of the BCK clock at all times for proper operation of the digital I/O data interface
2. The sampling frequency range is from 8 to 55 kHz
3. For MSB- and LSB-justified formats it is important to have a WS signal with a duty factor of 50%.

### Analog-to-Digital Converter (ADC)

The stereo ADC of the UDA1344TS consists of two 3rd-order Sigma-Delta modulators. They have a modified Ritchie-coder architecture in a differential switched capacitor implementation. The oversampling ratio is 128.

In contrast to the UDA1340M, the UDA1344TS supports 1 V (RMS) input signals and can be set, via an external resistor, to support 2 V (RMS) input signals.

### Analog front-end

The analog front-end is equipped with a selectable 0 dB or 6 dB gain block. The pin to select the gain switch is given in Section "L3 mode". This block can be used in applications in which both 1 V (RMS) and 2 V (RMS) input signals are available.

In applications in which a 2 V (RMS) input signal is used, a 12 kΩ resistor must be connected in series with the input of the ADC. This makes a voltage divider with the internal ADC resistor and makes sure only 1 V (RMS) maximum is input to the IC. Using this application for a 2 V (RMS) input signal, the gain switch must be set to 0 dB. When a 1 V (RMS) input signal is input to the ADC in the same application, the gain switch must be set to 6 dB.

An overview of the maximum input voltages allowed against the presence of an external resistor and the setting of the gain switch is given in Table 1.

**Table 1** Application modes using input gain stage

RESISTOR (12 kΩ)	INPUT GAIN SWITCH	MAXIMUM INPUT VOLTAGE
Present	0 dB	2 V (RMS)
Present	6 dB	1 V (RMS)
Absent	0 dB	1 V (RMS)
Absent	6 dB	0.5 V (RMS)

### Decimation filter (ADC)

The decimation from  $128f_s$  to  $1f_s$  is performed in 2 stages.

The first stage realizes 3rd-order  $\frac{\sin x}{x}$  characteristic. This filter decreases the sample rate by 16.

The second stage, a Finite Impulse Response (FIR) filter, consists of 3 half-band filters, each decimating by a factor of 2.

**Table 2** Decimation filter characteristics

ITEM	CONDITIONS	VALUE (dB)
Pass-band ripple	$0 - 0.45f_s$	$\pm 0.05$
Stop band	$> 0.55f_s$	-60
Dynamic range	$0 - 0.45f_s$	108
Overall gain with 0 dB input to the ADC	DC	-1.16

### DC-cancellation filter (ADC)

An optional Infinite Impulse-Response (IIR) high-pass filter is provided to remove unwanted DC components.

The operation is selected by the microcontroller via the L3 interface. The filter characteristics are given in Table 3.

**Table 3** DC-cancellation filter characteristics

ITEM	CONDITIONS	VALUE (dB)
Pass-band ripple	-	none
Pass-band gain	-	0
Droop	at $0.00045f_s$	0.031
Attenuation at DC	at $0.00000036f_s$	>40
Dynamic range	$0 - 0.45f_s$	>110

# Low-voltage low-power stereo audio CODEC with DSP features

## UDA1344TS

### Mute (ADC)

On recovery from power-down or switching on of the system clock, the serial data output on pin DATA0 is held at LOW level until valid data is available from the decimation filter. This time depends on whether the DC-cancellation filter is selected:

- DC cancel off:

$$t = \frac{1024}{f_s}; t = 23.2 \text{ ms at } f_s = 44.1 \text{ kHz}$$

- DC cancel on:

$$t = \frac{12288}{f_s}; t = 279 \text{ ms at } f_s = 44.1 \text{ kHz.}$$

### Interpolation filter (DAC)

The digital filter interpolates from  $1f_s$  to  $128f_s$  by means of a cascade of a recursive filter and an FIR filter.

**Table 4** Interpolation filter characteristics

ITEM	CONDITIONS	VALUE (dB)
Pass-band ripple	$0 - 0.45f_s$	$\pm 0.03$
Stop band	$>0.55f_s$	-50
Dynamic range	$0 - 0.45f_s$	108
Gain	DC	-3.5

### Noise shaper (DAC)

The 3rd-order noise shaper operates at  $128f_s$ . It shifts in-band quantization noise to frequencies well above the audio band. This noise shaping technique enables high signal-to-noise ratios to be achieved. The noise shaper output is converted into an analog signal using a Filter Stream Digital-to-Analog Converter (FSDAC).

### Filter stream DAC

The FSDAC is a semi-digital reconstruction filter that converts the 1-bit data stream of the noise shaper to an analog output voltage. The filter coefficients are implemented as current sources and are summed at virtual ground of the output operational amplifier. In this way very high signal-to-noise performance and low clock jitter sensitivity is achieved. A post-filter is not needed due to the inherent filter function of the DAC. On-board amplifiers convert the FSDAC output current to an output voltage signal capable of driving a line output.

The output voltage of the FSDAC scales proportionally with the power supply voltage.

### Multiple format input/output interface

The UDA1344TS supports the following data input/output formats:

- I<sup>2</sup>S-bus format with data word length of up to 20 bits
- MSB-justified serial format with data word length of up to 20 bits
- LSB-justified serial format with data word lengths of 16, 18 or 20 bits (in L3 mode only)
- Combined data formats:
  - L3 mode: MSB-justified data output and LSB-justified 16, 18 and 20 bits data input
  - Static pin mode: MSB-justified data output and LSB-justified 16 and 20 bits data input.

The formats are illustrated in Fig.3. Left and right data-channel words are time multiplexed.

### Control mode selection

The UDA1344TS can be used under L3 microcontroller interface control or static pin control. The mode can be set via the mode control pins MC1 and MC2 (see Table 5).

**Table 5** Mode control pins

PIN MC2	PIN MC1	MODE
LOW	LOW	L3 mode
LOW	HIGH	Test mode
HIGH	LOW	
HIGH	HIGH	Static pin mode

**Important:** in the L3 mode the UDA1344TS is completely pin and function compatible with the UDA1340M.

Low-voltage low-power stereo audio CODEC with DSP features

UDA1344TS

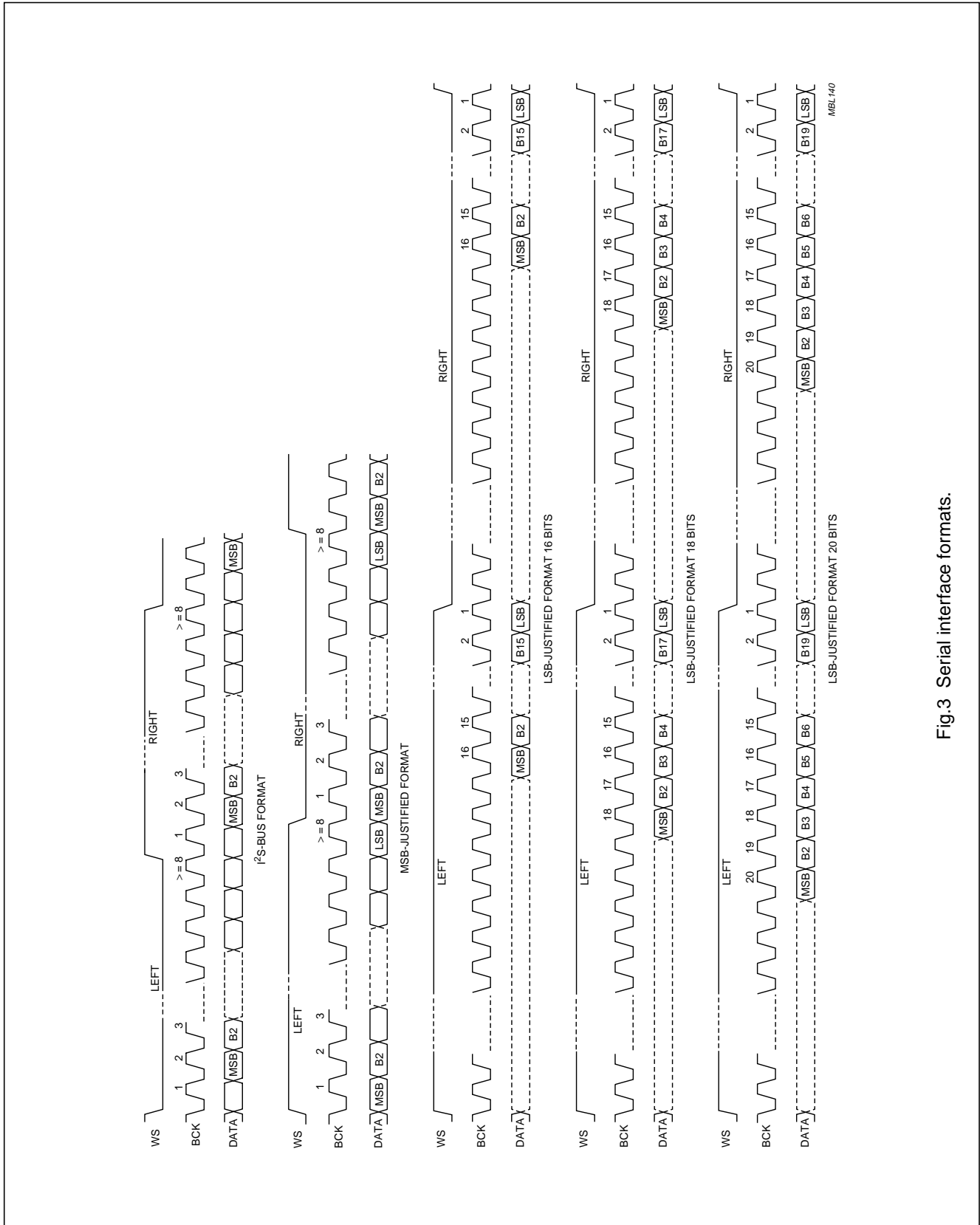

Fig.3 Serial interface formats.



## Low-voltage low-power stereo audio CODEC with DSP features

UDA1344TS

### Static pin mode

The UDA1344TS is set to static pin mode by setting both pins MC1 and MC2 to HIGH level.

The controllable features in this mode are:

- System clock frequency selection
- Data input/output format selection
- De-emphasis and mute control
- Power-down and ADC input level selection.

#### PINNING DEFINITION

The pinning definition in the static pin mode is given in Table 6.

**Table 6** Pinning definition in static pin model

PIN	DESCRIPTION
MP1	data input/output setting
MP2	three-level pin to select no de-emphasis, de-emphasis or mute
MP3	256f <sub>s</sub> or 384f <sub>s</sub> system clock selection
MP4	three-level pin to select ADC power-down, ADC input 1 V (RMS) or ADC input 2 V (RMS)
MP5	data input/output setting

#### SYSTEM CLOCK

In the static pin mode the options are 256f<sub>s</sub> and 384f<sub>s</sub> as given in Table 7.

**Table 7** System clock selection

PIN MP3	SELECTION
LOW	256f <sub>s</sub> clock frequency
HIGH	384f <sub>s</sub> clock frequency

#### MUTE AND DE-EMPHASIS

The level definition of pin MP2 is given in Table 8.

**Table 8** Levels for pin MP2

PIN MP2	SELECTION
LOW	no de-emphasis and mute
0.5V <sub>DDD</sub>	de-emphasis 44.1 kHz
HIGH	mute

#### INPUT/OUTPUT DATA FORMAT SELECTION

The input/output data format can be selected using pins MP1 and MP5 as given in Table 9.

**Table 9** Data format selection

PIN MP1	PIN MP5	SELECTION
LOW	LOW	input: MSB-justified
LOW	HIGH	input: I <sup>2</sup> S-bus
HIGH	LOW	input: LSB-justified 20 bits; output: MSB-justified
HIGH	HIGH	input: LSB-justified 16 bits; output: MSB-justified

#### ADC INPUT VOLTAGE SELECTION AND POWER-DOWN

In the static pin mode the three-level pin MP4 is used to select 0 or 6 dB gain and power-down.

**Table 10** Levels for pin MP4

PIN MP4	SELECTION
LOW	ADC power-down
0.5V <sub>DDD</sub>	6 dB gain
HIGH	0 dB gain

## Low-voltage low-power stereo audio CODEC with DSP features

UDA1344TS

### L3 mode

The UDA1344TS is set to the L3 mode by setting both pins MC1 and MC2 to LOW level.

The static pins in this mode are used for:

- ADC output overload detection
- L3 interface signal input
- ADC input voltage selection.

The controllable features via the L3 interface and the definition of the control registers are given in Section "L3 interface".

#### PINNING DEFINITION

The pinning definition in the L3 mode is given in Table 11.

**Table 11** Pinning definition in L3 mode

PIN	FUNCTION
MP1	ADC output overload detection
MP2	L3MODE input
MP3	L3CLOCK input
MP4	L3DATA input
MP5	ADC input voltage selection: 1 V (RMS) or 2 V (RMS)

#### ADC OUTPUT OVERLOAD DETECTION

In practice the output is used to indicate whenever the output data, in either the left or right channel, is greater than  $-1$  dB (actual figure is  $-1.16$  dB) of the maximum possible digital swing. When this condition is detected pin MP1 is forced to HIGH level for at least  $512f_s$  cycles ( $11.6$  ms at  $f_s = 44.1$  kHz). This time-out is reset for each infringement.

#### ADC INPUT VOLTAGE SELECTION

In the L3 mode pin MP5 is used to select 0 or 6 dB gain.

**Table 12** Levels for pin MP5

PIN MP4	SELECTION
LOW	0 dB gain
HIGH	6 dB gain

## Low-voltage low-power stereo audio CODEC with DSP features

UDA1344TS

### L3 INTERFACE

The UDA1344TS has a microcontroller input mode. In the microcontroller control mode, all the digital sound processing features and the system controlling features can be controlled by the microcontroller. The controllable features are:

- System clock frequency
- Data input format
- Power control
- DC filtering
- De-emphasis
- Volume
- Flat/min./max. switch
- Bass boost
- Treble
- Mute.

The exchange of data and control information between the microcontroller and the UDA1344TS is accomplished through a serial hardware interface comprising the following lines:

L3DATA: microcontroller interface data line

L3MODE: microcontroller interface mode line

L3CLOCK: microcontroller interface clock line.

Information transfer via the microcontroller bus is LSB first and is organized in accordance with the so called 'L3' format, in which two different modes of operation can be distinguished: address mode and data transfer mode.

The address mode is required to select a device communicating via the L3 interface and to define the destination registers for the data transfer mode. Data transfer for the UDA1344TS can only be in one direction: input to the UDA1344TS to program its sound processing and other functional features.

#### Address mode

The address mode is used to select a device for subsequent data transfer and to define the destination registers. The address mode is characterized by L3MODE being LOW and a burst of 8 pulses on L3CLOCK, accompanied by 8 data bits.

The fundamental timing is shown in Fig.4.

Data bits 7 to 2 represent a 6-bit device address, with bit 7 being the MSB and bit 2 the LSB. The address of the UDA1344TS is 000101 (bits 7 to 2).

Data bits 1 and 0 indicate the type of subsequent data transfer as given in Table 13.

**Table 13** Selection of data transfer

BIT 1	BIT 0	TRANSFER
0	0	data (volume, bass boost, treble, de-emphasis, mute, mode and power control)
0	1	not used
1	0	status (system clock frequency, data input/output format and DC filter)
1	1	not used

In the event that the UDA1344TS receives a different address, it will deselect its microcontroller interface logic.

#### Data transfer mode

The selection performed in the address mode remains active during subsequent data transfers, until the UDA1344TS receives a new address command.

The fundamental timing of data transfers is essentially the same as in the address mode and is shown in Fig.5.

The maximum input clock and data rate is  $64f_s$ . All transfers are byte wise, i.e. they are based on groups of 8 bits. Data will be stored in the UDA1344TS after the eighth bit of a byte has been received.

A multibyte data transfer is illustrated in Fig.6.

#### Programming the sound processing and other features

The sound processing and other feature values are stored in independent registers.

The first selection of the registers is achieved by the choice of data type that is transferred. This is performed in the address mode by bit 1 and bit 0 (see Table 13).

The second selection is performed by the 2 MSBs of the data byte (bit 7 and bit 6).

The other bits in the data byte (bits 5 to 0) is the value that is placed in the selected registers.

Low-voltage low-power stereo audio CODEC with DSP features

UDA1344TS

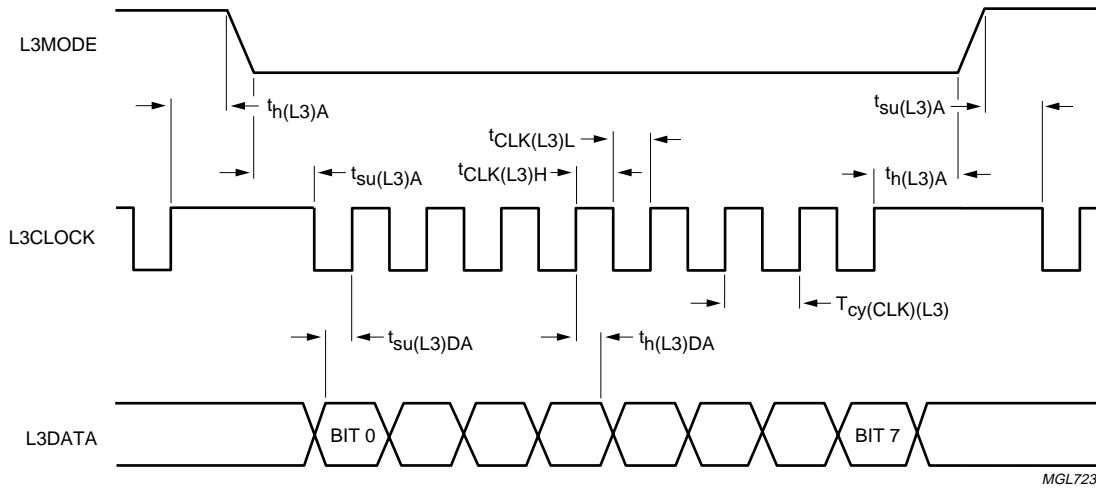

Fig.4 Timing in address mode.

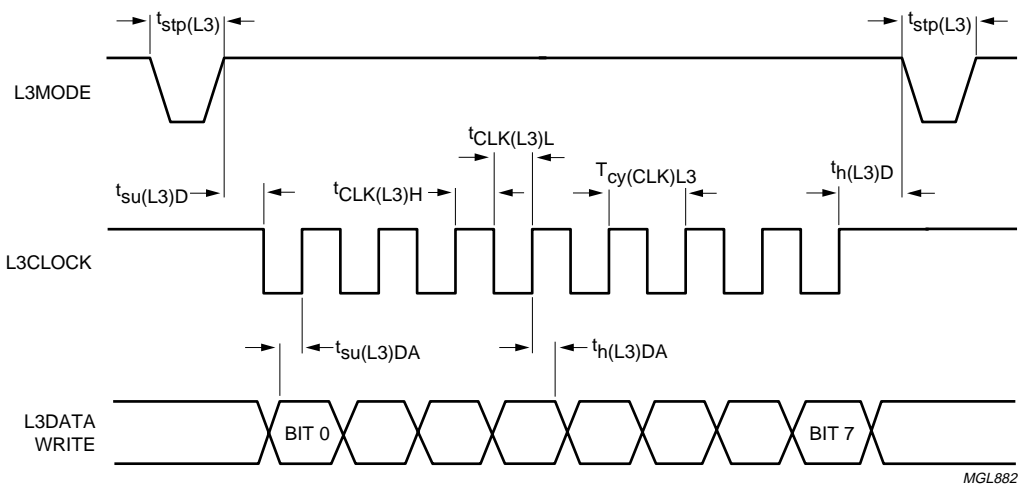

Fig.5 Timing in data transfer mode.

Low-voltage low-power stereo audio  
CODEC with DSP features

UDA1344TS

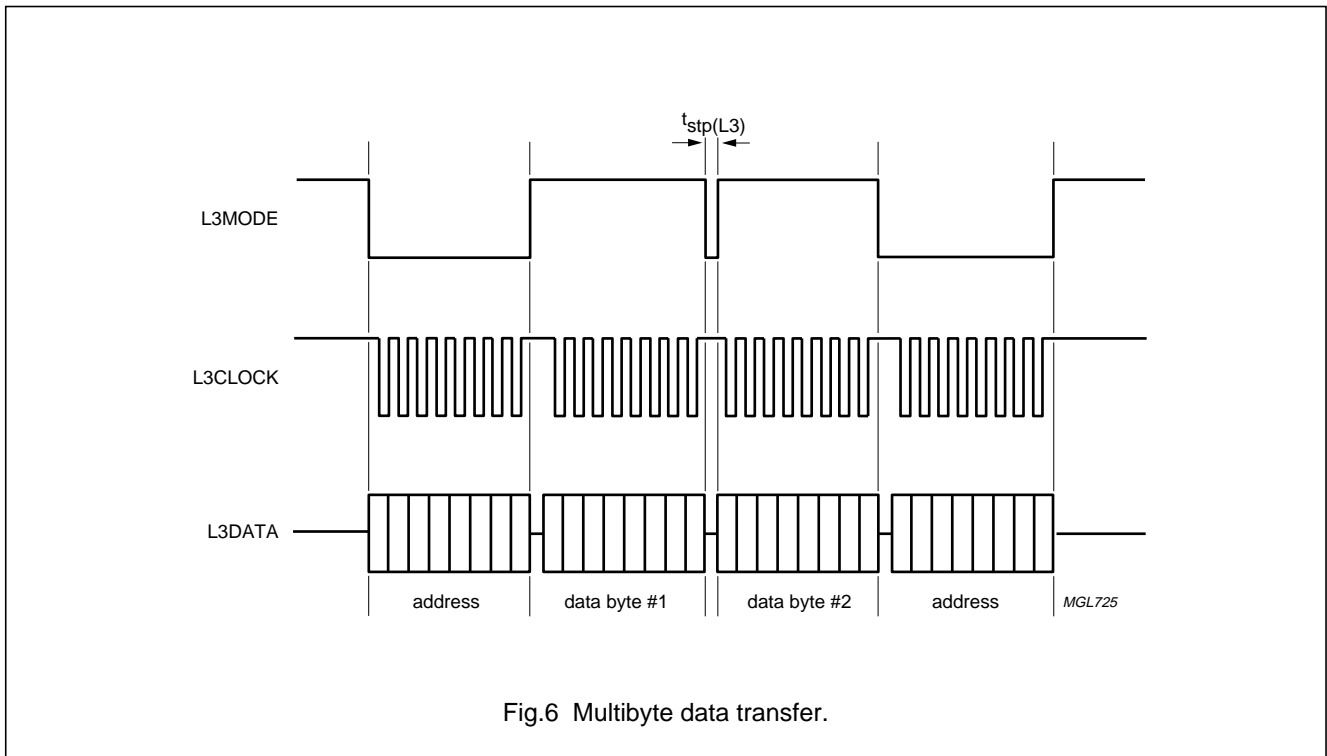

Fig.6 Multibyte data transfer.

**L3 interface registers**

When the data transfer of type 'status' is selected, the features system clock frequency, data input format and DC filter can be controlled.

**Table 14** Data transfer of type 'status'

BIT 7	BIT 6	BIT 5	BIT 4	BIT 3	BIT 2	BIT 1	BIT 0	REGISTER SELECTED
0	0	SC1	SC0	IF2	IF1	IF0	DC	SC = system clock frequency (2 bits); see Table 16
								IF = data input format (3 bits); see Table 17
								DC = DC filter (1 bit); see Table 18

When the data transfer of type 'data' is selected, the features volume, bass boost, treble, de-emphasis, mute, mode and power control can be controlled.

**Table 15** Data transfer of type 'data'

BIT 7	BIT 6	BIT 5	BIT 4	BIT 3	BIT 2	BIT 1	BIT 0	REGISTER SELECTED
0	0	VC5	VC4	VC3	VC2	VC1	VC0	VC = volume control (6 bits); see Table 19
0	1	BB3	BB2	BB1	BB0	TR1	TR0	BB = bass boost (4 bits); see Table 20
								TR = treble (2 bits); see Table 21
1	0	0	DE1	DE0	MT	M1	M0	DE = de-emphasis (2 bits); see Table 22
								MT = mute (1 bit); see Table 23
								M = filter mode (2 bits); see Table 24
1	1	0	0	0	0	PC1	PC0	PC = power control (2 bits); see Table 25

# Low-voltage low-power stereo audio CODEC with DSP features

UDA1344TS

## SYSTEM CLOCK FREQUENCY

A 2-bit value to select the used external clock frequency.

**Table 16** System clock frequency settings

SC1	SC0	SELECTION
0	0	512f <sub>s</sub>
0	1	384f <sub>s</sub>
1	0	256f <sub>s</sub>
1	1	not used

## DATA INPUT FORMAT

A 3-bit value to select the used data format.

**Table 17** Data format settings

IF2	IF1	IF0	FORMAT
0	0	0	I <sup>2</sup> S-bus
0	0	1	LSB-justified 16 bits
0	1	0	LSB-justified 18 bits
0	1	1	LSB-justified 20 bits
1	0	0	MSB-justified
1	0	1	input: LSB-justified 16 bits; output: MSB-justified
1	1	0	input: LSB-justified 18 bits; output: MSB-justified
1	1	1	input: LSB-justified 20 bits; output: MSB-justified

## DC FILTER

A 1-bit value to enable the digital DC filter.

**Table 18** DC filtering

DC	SELECTION
0	no DC filtering
1	DC filtering

## VOLUME CONTROL

A 6-bit value to program the left and right channel volume attenuation. The range is from 0 to -∞ dB in steps of 1 dB.

**Table 19** Volume settings

VC5	VC4	VC3	VC2	VC1	VC0	VOLUME (dB)
0	0	0	0	0	0	0
0	0	0	0	0	1	0
0	0	0	0	1	0	-1
0	0	0	0	1	1	-2
:	:	:	:	:	:	:
1	1	1	0	1	1	-58
1	1	1	1	0	0	-59
1	1	1	1	0	1	-60
1	1	1	1	1	0	-∞
1	1	1	1	1	1	-∞

## BASS BOOST

A 4-bit value to program the bass boost setting. The used set depends on the mode bits M1 and M0.

**Table 20** Bass boost settings

BB3	BB2	BB1	BB0	BASS BOOST SETTING		
				FLAT (dB)	MIN. (dB)	MAX. (dB)
0	0	0	0	0	0	0
0	0	0	1	0	2	2
0	0	1	0	0	4	4
0	0	1	1	0	6	6
0	1	0	0	0	8	8
0	1	0	1	0	10	10
0	1	1	0	0	12	12
0	1	1	1	0	14	14
1	0	0	0	0	16	16
1	0	0	1	0	18	18
1	0	1	0	0	18	20
1	0	1	1	0	18	22
1	1	0	0	0	18	24
1	1	0	1	0	18	24
1	1	1	0	0	18	24
1	1	1	1	0	18	24

# Low-voltage low-power stereo audio CODEC with DSP features

UDA1344TS

## TREBLE

A 2-bit value to program the treble setting. The used set depends on the mode bits M1 and M0.

**Table 21** Treble settings

TR1	TR0	TREBLE SETTING		
		FLAT (dB)	MIN. (dB)	MAX. (dB)
0	0	0	0	0
0	1	0	2	2
1	0	0	4	4
1	1	0	6	6

## DE-EMPHASIS

A 2-bit value to enable the digital de-emphasis filter.

**Table 22** De-emphasis settings

DE1	DE0	SELECTION
0	0	no de-emphasis
0	1	de-emphasis 32 kHz
1	0	de-emphasis 44.1 kHz
1	1	de-emphasis 48 kHz

## MUTE

A 1-bit value to enable the digital mute.

**Table 23** Mute

MT	SELECTION
0	no muting
1	muting

## MODE

A 2-bit value to program the mode of the sound processing filters of bass boost and treble.

**Table 24** Flat/min./max. switch

M1	M0	SELECTION
0	0	flat
0	1	min.
1	0	min.
1	1	max.

## POWER CONTROL

A 2-bit value to disable the ADC and/or DAC to reduce power consumption.

**Table 25** Power control settings

PC1	PC0	SELECTION	
		ADC	DAC
0	0	off	off
0	1	off	on
1	0	on	off
1	1	on	on

# Low-voltage low-power stereo audio CODEC with DSP features

UDA1344TS

## LIMITING VALUES

In accordance with the Absolute Maximum Rating System (IEC 60134).

SYMBOL	PARAMETER	CONDITIONS	MIN.	MAX.	UNIT
$V_{DDD}$	digital supply voltage		–	5.0	V
$T_{xtal(max)}$	maximum crystal temperature		–	150	°C
$T_{stg}$	storage temperature		–65	+125	°C
$T_{amb}$	ambient temperature		–40	+85	°C
$V_{es}$	electrostatic handling voltage	note 1	–3000	+3000	V
		note 2	–300	+300	V
$I_{lu(prot)}$	latch-up protection current	$T_{amb} = 25\text{ °C}; V_{DD} = 3.6\text{ V}$	–	200	mA
$I_{sc(DAC)}$	DAC short-circuit current: output short-circuited to $V_{SSA(DAC)}$ output short-circuited to $V_{DDA(DAC)}$	$T_{amb} = 0\text{ °C}; V_{DDA} = 3.0\text{ V}; \text{note 3}$	–	482	mA
			–	346	mA

## Notes

- Equivalent to discharging a 100 pF capacitor via a 1.5 kΩ series resistor.
- Equivalent to discharging a 200 pF capacitor via a 2.5 μH series inductor.
- DAC operation cannot be guaranteed after a short-circuit has occurred.

## THERMAL CHARACTERISTICS

SYMBOL	PARAMETER	CONDITIONS	VALUE	UNIT
$R_{th(j-a)}$	thermal resistance from junction to ambient	in free air	90	K/W

## DC CHARACTERISTICS

$V_{DDD} = V_{DDA} = V_{DDO} = 3.0\text{ V}; T_{amb} = 25\text{ °C}; R_L = 5\text{ k}\Omega$ ; all voltages referenced to ground; unless otherwise specified.

SYMBOL	PARAMETER	CONDITIONS	MIN.	TYP.	MAX.	UNIT
<b>Supplies; note 1</b>						
$V_{DDA(ADC)}$	ADC analog supply voltage		2.7	3.0	3.6	V
$V_{DDA(DAC)}$	DAC analog supply voltage		2.7	3.0	3.6	V
$V_{DDO}$	operational amplifier supply voltage		2.7	3.0	3.6	V
$V_{DDD}$	digital supply voltage		2.7	3.0	3.6	V
$I_{DDA(ADC)}$	ADC analog supply current	operating	–	9.0	11.0	mA
		ADC power-down	–	3.5	5.0	mA
$I_{DDA(DAC)}$	DAC analog supply current	operating	–	4.0	6.0	mA
		DAC power-down	–	25	75	μA
$I_{DDO}$	operational amplifier supply current	operating	–	4.0	6.0	mA
		DAC power-down	–	250	300	μA
$I_{DDD}$	digital supply current	operating	–	6.0	9.0	mA
		DAC power-down	–	2.5	4.0	mA
		ADC power-down	–	3.5	5.0	mA



# Low-voltage low-power stereo audio CODEC with DSP features

UDA1344TS

SYMBOL	PARAMETER	CONDITIONS	MIN.	TYP.	MAX.	UNIT
<b>Digital inputs</b>						
$V_{IH}$	HIGH-level input voltage		$0.8V_{DDD}$	–	$V_{DDD} + 0.5$	V
$V_{IL}$	LOW-level input voltage		–0.5	–	$0.2V_{DDD}$	V
$ I_{LI} $	input leakage current		–	–	10	$\mu\text{A}$
$C_i$	input capacitance		–	–	10	pF
<b>Digital outputs</b>						
$V_{OH}$	HIGH-level output voltage	$I_{OH} = -2 \text{ mA}$	$0.85V_{DDD}$	–	–	V
$V_{OL}$	LOW-level output voltage	$I_{OL} = 2 \text{ mA}$	–	–	0.4	V
<b>Three-level inputs: pins MP2 and MP4</b>						
$V_{IH}$	HIGH-level input voltage		$0.9V_{DDD}$	–	$V_{DDD} + 0.5$	V
$V_{IM}$	MIDDLE-level input voltage		$0.4V_{DDD}$	–	$0.6V_{DDD}$	V
$V_{IL}$	LOW-level input voltage		–0.5	–	$0.1V_{DDD}$	V
<b>Analog-to-digital converter</b>						
$V_{ref(A)}$	reference voltage	refererred to $V_{SSA(ADC)}$	$0.45V_{DDA}$	$0.5V_{DDA}$	$0.55V_{DDA}$	V
$R_{o(refA)}$	output resistance on pin $V_{ref(A)}$		–	24	–	$\text{k}\Omega$
$R_i$	input resistance	$f_i = 1 \text{ kHz}$	–	9.8	–	$\text{k}\Omega$
$C_i$	input capacitance		–	20	–	pF
<b>Digital-to-analog converter</b>						
$V_{ref(D)}$	reference voltage	refererred to $V_{SSA(DAC)}$	$0.45V_{DDA}$	$0.5V_{DDA}$	$0.55V_{DDA}$	V
$R_{o(refD)}$	output resistance on pin $V_{ref(D)}$		–	28	–	$\text{k}\Omega$
$R_o$	output resistance of DAC		–	0.13	3.0	$\Omega$
$I_{o(max)}$	maximum output current	$(\text{THD} + \text{N})/\text{S} < 0.1\%$ ; $R_L = 5 \text{ k}\Omega$	–	0.22	–	mA
$R_L$	load resistance		3	–	–	$\text{k}\Omega$
$C_L$	load capacitance	note 2	–	–	200	pF

**Notes**

1. All power supply pins ( $V_{DD}$  and  $V_{SS}$ ) must be connected to the same external power supply unit.
2. When higher capacitive loads must be driven, a  $100 \Omega$  resistor must be connected in series with the DAC output in order to prevent oscillations in the output operational amplifier.

# Low-voltage low-power stereo audio CODEC with DSP features

UDA1344TS

## AC CHARACTERISTICS

$V_{DD} = V_{DDA} = V_{DDO} = 3.0\text{ V}$ ;  $f_i = 1\text{ kHz}$ ;  $T_{amb} = 25\text{ °C}$ ;  $R_L = 5\text{ k}\Omega$ ; all voltages referenced to ground; unless otherwise specified.

SYMBOL	PARAMETER	CONDITIONS	TYP.	MAX.	UNIT
<b>Analog-to-digital converter</b>					
$V_{i(rms)}$	input voltage (RMS value)	notes 1 and 2	1.0	–	V
$\Delta V_i$	unbalance between channels		0.1	–	dB
(THD + N)/S	total harmonic distortion-plus-noise to signal ratio	at 0 dB	–85	–80	dB
		at –60 dB; A-weighted	–35	–30	dB
S/N	signal-to-noise ratio	$V_i = 0\text{ V}$ ; A-weighted	95	–	dB
$\alpha_{cs}$	channel separation		100	–	dB
PSRR	power supply rejection ratio	$f_{ripple} = 1\text{ kHz}$ ; $V_{ripple} = 300\text{ mV (p-p)}$	30	–	dB
<b>Digital-to-analog converter</b>					
$V_{o(rms)}$	output voltage (RMS value)	notes 3 and 4	900	–	mV
$\Delta V_o$	unbalance between channels		0.1	–	dB
(THD + N)/S	total harmonic distortion-plus-noise to signal ratio	at 0 dB	–90	–85	dB
		at –60 dB; A-weighted	–37	–	dB
S/N	signal-to-noise ratio	code = 0; A-weighted	100	–	dB
$\alpha_{cs}$	channel separation		100	–	dB
PSRR	power supply rejection ratio	$f_{ripple} = 1\text{ kHz}$ ; $V_{ripple} = 300\text{ mV (p-p)}$	50	–	dB

### Notes

1. The input voltage can be up to 2 V (RMS) when the current through the ADC input pin is limited to approximately 1 mA by using a series resistor.
2. The input voltage to the ADC is inversely proportional with the supply voltage.
3. The output voltage of the UDA1344TS differs from the output voltage of the UDA1340M.
4. The output of the DAC scales proportionally with the supply voltage.

# Low-voltage low-power stereo audio CODEC with DSP features

UDA1344TS

**TIMING**

$V_{DD} = V_{DDA} = V_{DDO} = 2.7$  to  $3.6$  V;  $T_{amb} = -40$  to  $+85$  °C;  $R_L = 5$  k $\Omega$ ; all voltages referenced to ground; unless otherwise specified.

SYMBOL	PARAMETER	CONDITIONS	MIN.	TYP.	MAX.	UNIT
<b>System clock input</b> (see Fig.7)						
$T_{sys}$	system clock cycle time	$f_{sys} = 256f_s$	78	88	–	ns
		$f_{sys} = 384f_s$	52	59	–	ns
		$f_{sys} = 512f_s$	39	44	–	ns
$t_{CWH}$	system clock HIGH time	$f_{sys} < 19.2$ MHz	$0.30T_{sys}$	–	$0.70T_{sys}$	ns
		$f_{sys} \geq 19.2$ MHz	$0.40T_{sys}$	–	$0.60T_{sys}$	ns
$t_{CWL}$	system clock LOW time	$f_{sys} < 19.2$ MHz	$0.30T_{sys}$	–	$0.70T_{sys}$	ns
		$f_{sys} \geq 19.2$ MHz	$0.40T_{sys}$	–	$0.60T_{sys}$	ns
<b>Serial interface input/output data</b> (see Fig.8)						
$f_{BCK}$	bit clock frequency		–	–	$64f_s$	Hz
$T_{cy(BCK)}$	bit clock cycle time	$T_{cy(s)} =$ cycle time of sample frequency	$\frac{T_{cy(s)}}{64}$	–	–	ns
$t_{BCKH}$	bit clock HIGH time		100	–	–	ns
$t_{BCKL}$	bit clock LOW time		100	–	–	ns
$t_r$	rise time		–	–	20	ns
$t_f$	fall time		–	–	20	ns
$t_{su(WS)}$	word select set-up time		20	–	–	ns
$t_{h(WS)}$	word select hold time		10	–	–	ns
$t_{su(DATAI)}$	data input set-up time		20	–	–	ns
$t_{h(DATAI)}$	data input hold time		0	–	–	ns
$t_{h(DATAO)}$	data output hold time		0	–	–	ns
$t_{d(DATAO-BCK)}$	data output to bit clock delay	from BCK falling edge	–	–	80	ns
$t_{d(DATAO-WS)}$	data output to word select delay	from WS edge for MSB-justified format	–	–	80	ns
<b>L3 interface input</b> (see Figs 4 and 5)						
$T_{cy(CLK)L3}$	L3CLOCK cycle time		500	–	–	ns
$t_{CLK(L3)H}$	L3CLOCK HIGH time		250	–	–	ns
$t_{CLK(L3)L}$	L3CLOCK LOW time		250	–	–	ns
$t_{su(L3)A}$	L3MODE set-up time for address mode		190	–	–	ns
$t_{h(L3)A}$	L3MODE hold time for address mode		190	–	–	ns
$t_{su(L3)D}$	L3MODE set-up time for data transfer mode		190	–	–	ns
$t_{h(L3)D}$	L3MODE hold time for data transfer mode		190	–	–	ns
$t_{stp(L3)}$	L3MODE stop time		190	–	–	ns
$t_{su(L3)DA}$	L3DATA set-up time in data transfer and address mode		190	–	–	ns
$t_{h(L3)DA}$	L3DATA hold time in data transfer and address mode		30	–	–	ns

Low-voltage low-power stereo audio  
CODEC with DSP features

UDA1344TS

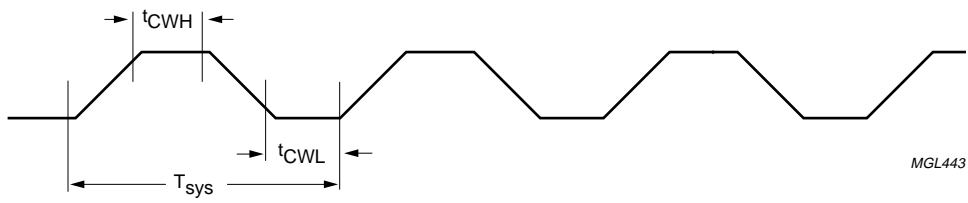

Fig.7 System clock timing.

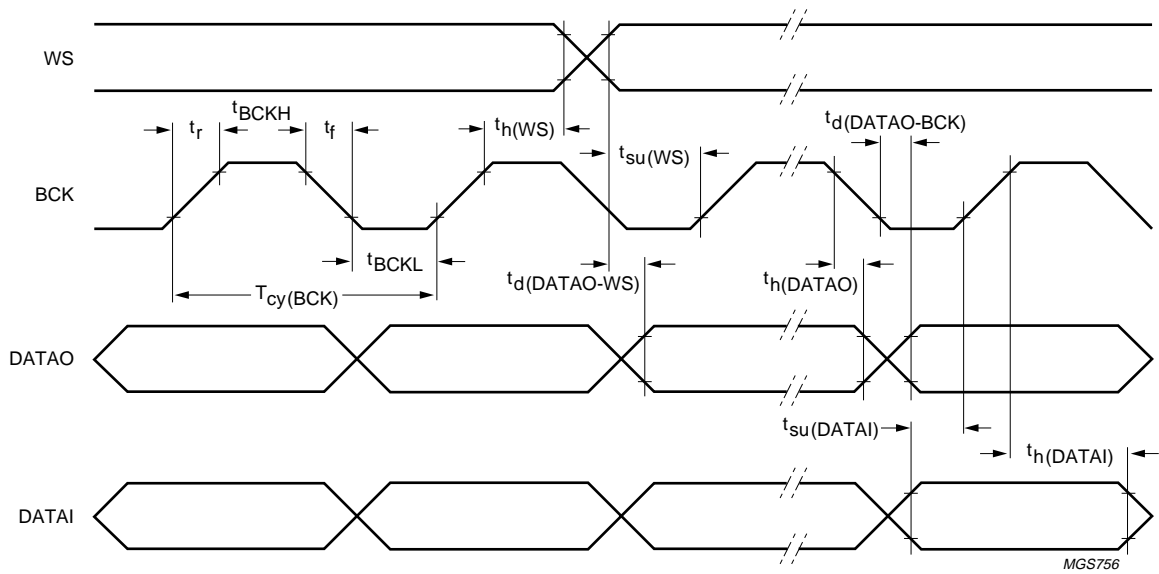

Fig.8 Serial interface timing.

# Low-voltage low-power stereo audio CODEC with DSP features

## UDA1344TS

### APPLICATION INFORMATION

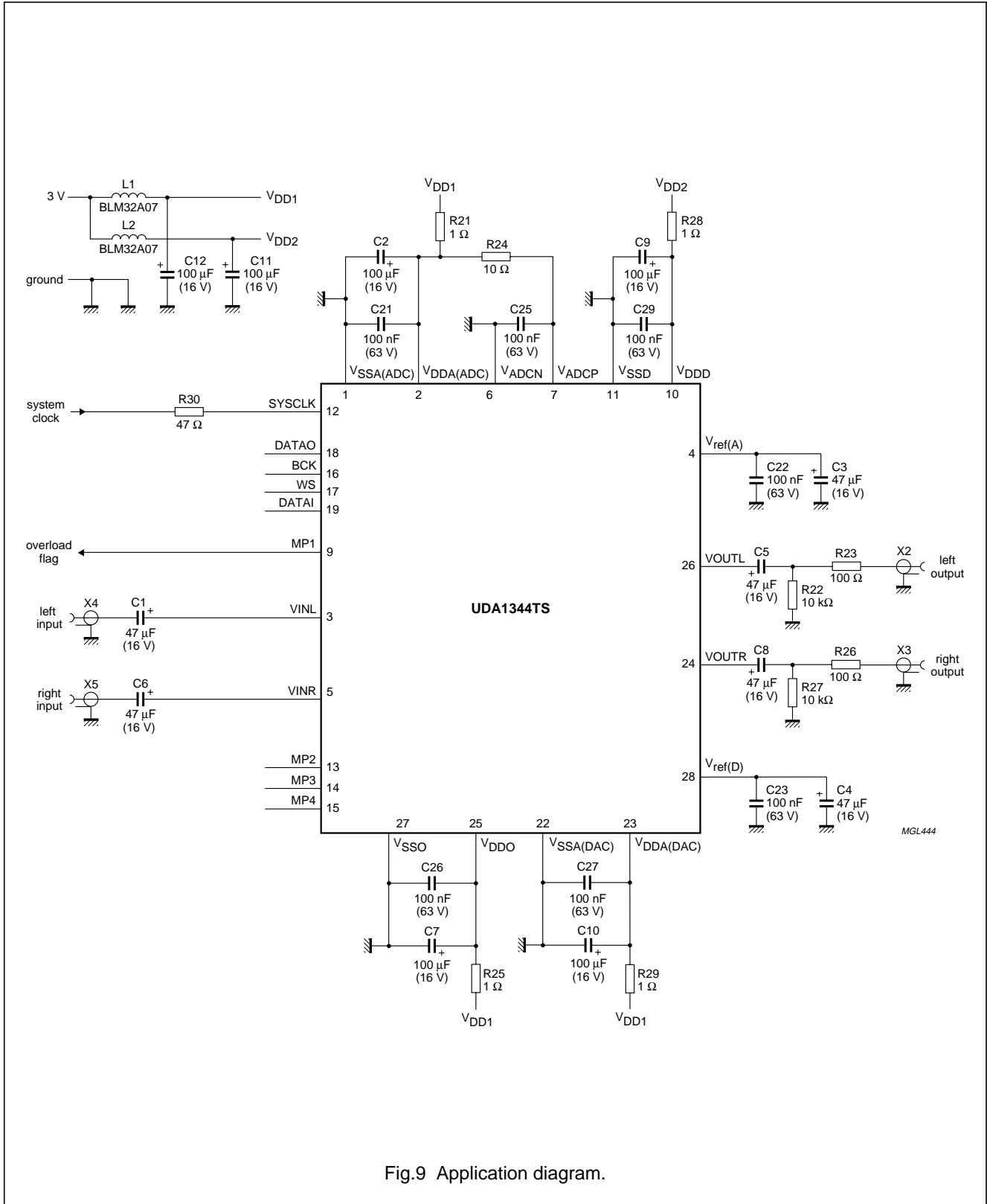

Fig.9 Application diagram.

Low-voltage low-power stereo audio  
CODEC with DSP features

UDA1344TS

PACKAGE OUTLINE

SSOP28: plastic shrink small outline package; 28 leads; body width 5.3 mm

SOT341-1

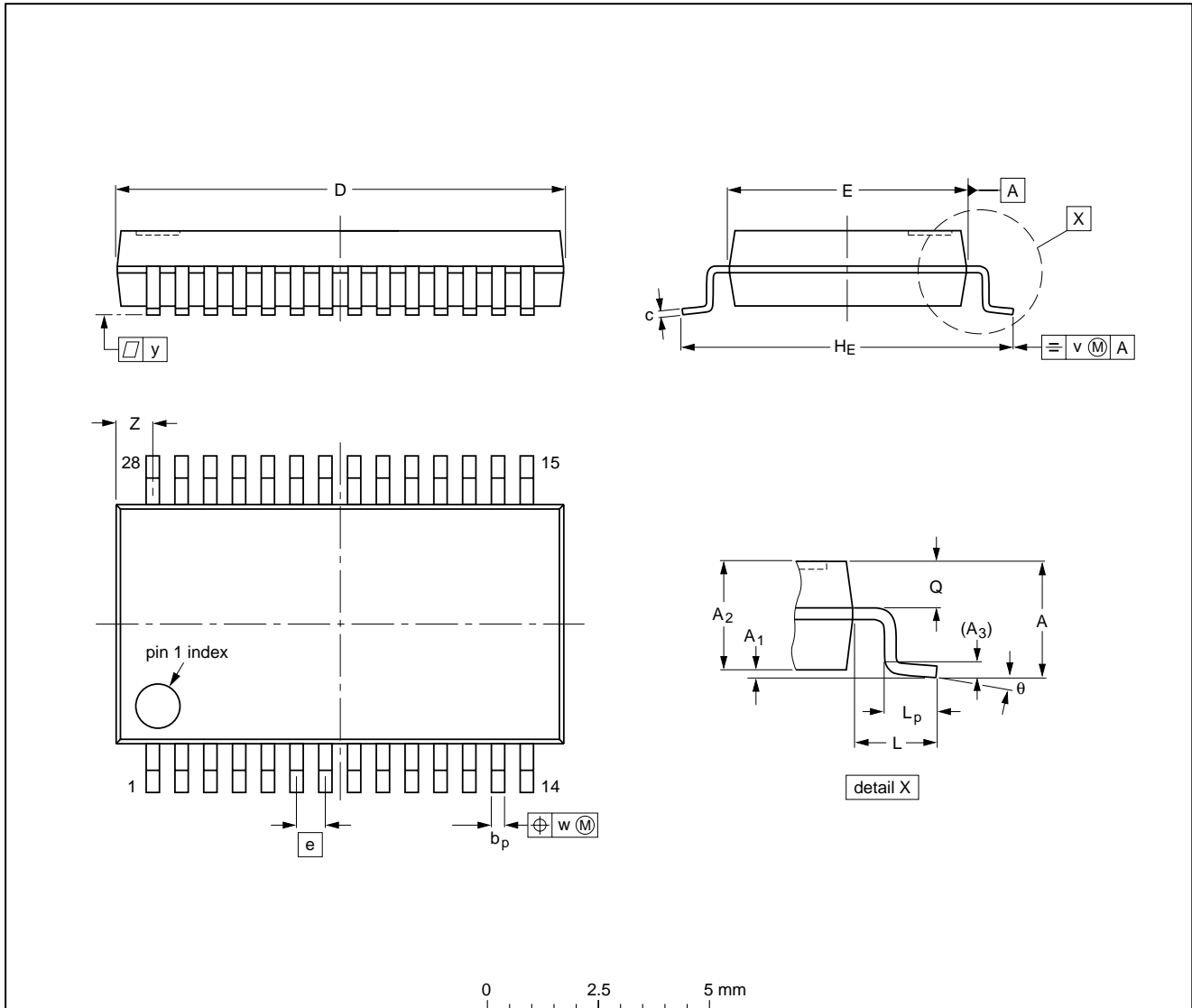

DIMENSIONS (mm are the original dimensions)

UNIT	A max.	A <sub>1</sub>	A <sub>2</sub>	A <sub>3</sub>	b <sub>p</sub>	c	D <sup>(1)</sup>	E <sup>(1)</sup>	e	H <sub>E</sub>	L	L <sub>p</sub>	Q	v	w	y	Z <sup>(1)</sup>	θ
mm	2.0	0.21 0.05	1.80 1.65	0.25	0.38 0.25	0.20 0.09	10.4 10.0	5.4 5.2	0.65	7.9 7.6	1.25	1.03 0.63	0.9 0.7	0.2	0.13	0.1	1.1 0.7	8° 0°

Note

1. Plastic or metal protrusions of 0.20 mm maximum per side are not included.

OUTLINE VERSION	REFERENCES				EUROPEAN PROJECTION	ISSUE DATE
	IEC	JEDEC	EIAJ			
SOT341-1		MO-150				95-02-04 99-12-27

## Low-voltage low-power stereo audio CODEC with DSP features

UDA1344TS

### SOLDERING

#### Introduction to soldering surface mount packages

This text gives a very brief insight to a complex technology. A more in-depth account of soldering ICs can be found in our *"Data Handbook IC26; Integrated Circuit Packages"* (document order number 9398 652 90011).

There is no soldering method that is ideal for all surface mount IC packages. Wave soldering can still be used for certain surface mount ICs, but it is not suitable for fine pitch SMDs. In these situations reflow soldering is recommended.

#### Reflow soldering

Reflow soldering requires solder paste (a suspension of fine solder particles, flux and binding agent) to be applied to the printed-circuit board by screen printing, stencilling or pressure-syringe dispensing before package placement.

Several methods exist for reflowing; for example, convection or convection/infrared heating in a conveyor type oven. Throughput times (preheating, soldering and cooling) vary between 100 and 200 seconds depending on heating method.

Typical reflow peak temperatures range from 215 to 250 °C. The top-surface temperature of the packages should preferably be kept below 220 °C for thick/large packages, and below 235 °C for small/thin packages.

#### Wave soldering

Conventional single wave soldering is not recommended for surface mount devices (SMDs) or printed-circuit boards with a high component density, as solder bridging and non-wetting can present major problems.

To overcome these problems the double-wave soldering method was specifically developed.

If wave soldering is used the following conditions must be observed for optimal results:

- Use a double-wave soldering method comprising a turbulent wave with high upward pressure followed by a smooth laminar wave.
- For packages with leads on two sides and a pitch (e):
  - larger than or equal to 1.27 mm, the footprint longitudinal axis is **preferred** to be parallel to the transport direction of the printed-circuit board;
  - smaller than 1.27 mm, the footprint longitudinal axis **must** be parallel to the transport direction of the printed-circuit board.

The footprint must incorporate solder thieves at the downstream end.

- For packages with leads on four sides, the footprint must be placed at a 45° angle to the transport direction of the printed-circuit board. The footprint must incorporate solder thieves downstream and at the side corners.

During placement and before soldering, the package must be fixed with a droplet of adhesive. The adhesive can be applied by screen printing, pin transfer or syringe dispensing. The package can be soldered after the adhesive is cured.

Typical dwell time is 4 seconds at 250 °C.

A mildly-activated flux will eliminate the need for removal of corrosive residues in most applications.

#### Manual soldering

Fix the component by first soldering two diagonally-opposite end leads. Use a low voltage (24 V or less) soldering iron applied to the flat part of the lead. Contact time must be limited to 10 seconds at up to 300 °C.

When using a dedicated tool, all other leads can be soldered in one operation within 2 to 5 seconds between 270 and 320 °C.

# Low-voltage low-power stereo audio CODEC with DSP features

UDA1344TS

## Suitability of surface mount IC packages for wave and reflow soldering methods

PACKAGE	SOLDERING METHOD	
	WAVE	REFLOW <sup>(1)</sup>
BGA, HBGA, LFBGA, SQFP, TFBGA	not suitable	suitable
HBCC, HLQFP, HSQFP, HSOP, HTQFP, HTSSOP, HVQFN, SMS	not suitable <sup>(2)</sup>	suitable
PLCC <sup>(3)</sup> , SO, SOJ	suitable	suitable
LQFP, QFP, TQFP	not recommended <sup>(3)(4)</sup>	suitable
SSOP, TSSOP, VSO	not recommended <sup>(5)</sup>	suitable

### Notes

1. All surface mount (SMD) packages are moisture sensitive. Depending upon the moisture content, the maximum temperature (with respect to time) and body size of the package, there is a risk that internal or external package cracks may occur due to vaporization of the moisture in them (the so called popcorn effect). For details, refer to the Drypack information in the *"Data Handbook IC26; Integrated Circuit Packages; Section: Packing Methods"*.
2. These packages are not suitable for wave soldering as a solder joint between the printed-circuit board and heatsink (at bottom version) can not be achieved, and as solder may stick to the heatsink (on top version).
3. If wave soldering is considered, then the package must be placed at a 45° angle to the solder wave direction. The package footprint must incorporate solder thieves downstream and at the side corners.
4. Wave soldering is only suitable for LQFP, TQFP and QFP packages with a pitch (e) equal to or larger than 0.8 mm; it is definitely not suitable for packages with a pitch (e) equal to or smaller than 0.65 mm.
5. Wave soldering is only suitable for SSOP and TSSOP packages with a pitch (e) equal to or larger than 0.65 mm; it is definitely not suitable for packages with a pitch (e) equal to or smaller than 0.5 mm.



# Low-voltage low-power stereo audio CODEC with DSP features

UDA1344TS

## DATA SHEET STATUS

DATA SHEET STATUS <sup>(1)</sup>	PRODUCT STATUS <sup>(2)</sup>	DEFINITIONS
Objective data	Development	This data sheet contains data from the objective specification for product development. Philips Semiconductors reserves the right to change the specification in any manner without notice.
Preliminary data	Qualification	This data sheet contains data from the preliminary specification. Supplementary data will be published at a later date. Philips Semiconductors reserves the right to change the specification without notice, in order to improve the design and supply the best possible product.
Product data	Production	This data sheet contains data from the product specification. Philips Semiconductors reserves the right to make changes at any time in order to improve the design, manufacturing and supply. Changes will be communicated according to the Customer Product/Process Change Notification (CPCN) procedure SNW-SQ-650A.

### Notes

1. Please consult the most recently issued data sheet before initiating or completing a design.
2. The product status of the device(s) described in this data sheet may have changed since this data sheet was published. The latest information is available on the Internet at URL <http://www.semiconductors.philips.com>.

### DEFINITIONS

**Short-form specification** — The data in a short-form specification is extracted from a full data sheet with the same type number and title. For detailed information see the relevant data sheet or data handbook.

**Limiting values definition** — Limiting values given are in accordance with the Absolute Maximum Rating System (IEC 60134). Stress above one or more of the limiting values may cause permanent damage to the device. These are stress ratings only and operation of the device at these or at any other conditions above those given in the Characteristics sections of the specification is not implied. Exposure to limiting values for extended periods may affect device reliability.

**Application information** — Applications that are described herein for any of these products are for illustrative purposes only. Philips Semiconductors make no representation or warranty that such applications will be suitable for the specified use without further testing or modification.

### DISCLAIMERS

**Life support applications** — These products are not designed for use in life support appliances, devices, or systems where malfunction of these products can reasonably be expected to result in personal injury. Philips Semiconductors customers using or selling these products for use in such applications do so at their own risk and agree to fully indemnify Philips Semiconductors for any damages resulting from such application.

**Right to make changes** — Philips Semiconductors reserves the right to make changes, without notice, in the products, including circuits, standard cells, and/or software, described or contained herein in order to improve design and/or performance. Philips Semiconductors assumes no responsibility or liability for the use of any of these products, conveys no licence or title under any patent, copyright, or mask work right to these products, and makes no representations or warranties that these products are free from patent, copyright, or mask work right infringement, unless otherwise specified.

---

Low-voltage low-power stereo audio  
CODEC with DSP features

---

UDA1344TS

**NOTES**

---

Low-voltage low-power stereo audio  
CODEC with DSP features

---

UDA1344TS

**NOTES**

# Philips Semiconductors – a worldwide company

**Argentina:** see South America

**Australia:** 3 Figtree Drive, HOMEBUSH, NSW 2140,  
Tel. +61 2 9704 8141, Fax. +61 2 9704 8139

**Austria:** Computerstr. 6, A-1101 WIEN, P.O. Box 213,  
Tel. +43 1 60 101 1248, Fax. +43 1 60 101 1210

**Belarus:** Hotel Minsk Business Center, Bld. 3, r. 1211, Volodarski Str. 6,  
220050 MINSK, Tel. +375 172 20 0733, Fax. +375 172 20 0773

**Belgium:** see The Netherlands

**Brazil:** see South America

**Bulgaria:** Philips Bulgaria Ltd., Energoproject, 15th floor,  
51 James Bourchier Blvd., 1407 SOFIA,  
Tel. +359 2 68 9211, Fax. +359 2 68 9102

**Canada:** PHILIPS SEMICONDUCTORS/COMPONENTS,  
Tel. +1 800 234 7381, Fax. +1 800 943 0087

**China/Hong Kong:** 501 Hong Kong Industrial Technology Centre,  
72 Tat Chee Avenue, Kowloon Tong, HONG KONG,  
Tel. +852 2319 7888, Fax. +852 2319 7700

**Colombia:** see South America

**Czech Republic:** see Austria

**Denmark:** Sydhavnsgade 23, 1780 COPENHAGEN V,  
Tel. +45 33 29 3333, Fax. +45 33 29 3905

**Finland:** Sinikalliontie 3, FIN-02630 ESPOO,  
Tel. +358 9 615 800, Fax. +358 9 6158 0920

**France:** 7 - 9 Rue du Mont Valérien, BP317, 92156 SURESNES Cedex,  
Tel. +33 1 4728 6600, Fax. +33 1 4728 6638

**Germany:** Hammerbrookstraße 69, D-20097 HAMBURG,  
Tel. +49 40 2353 60, Fax. +49 40 2353 6300

**Hungary:** Philips Hungary Ltd., H-1119 Budapest, Fehervari ut 84/A,  
Tel: +36 1 382 1700, Fax: +36 1 382 1800

**India:** Philips INDIA Ltd, Band Box Building, 2nd floor,  
254-D, Dr. Annie Besant Road, Worli, MUMBAI 400 025,  
Tel. +91 22 493 8541, Fax. +91 22 493 0966

**Indonesia:** PT Philips Development Corporation, Semiconductors Division,  
Gedung Philips, Jl. Buncit Raya Kav.99-100, JAKARTA 12510,  
Tel. +62 21 794 0040 ext. 2501, Fax. +62 21 794 0080

**Ireland:** Newstead, Clonskeagh, DUBLIN 14,  
Tel. +353 1 7640 000, Fax. +353 1 7640 200

**Israel:** RAPAC Electronics, 7 Kehilat Saloniki St, PO Box 18053,  
TEL AVIV 61180, Tel. +972 3 645 0444, Fax. +972 3 649 1007

**Italy:** PHILIPS SEMICONDUCTORS, Via Casati, 23 - 20052 MONZA (MI),  
Tel. +39 039 203 6838, Fax +39 039 203 6800

**Japan:** Philips Bldg 13-37, Kohnan 2-chome, Minato-ku,  
TOKYO 108-8507, Tel. +81 3 3740 5130, Fax. +81 3 3740 5057

**Korea:** Philips House, 260-199 Itaewon-dong, Yongsan-ku, SEOUL,  
Tel. +82 2 709 1412, Fax. +82 2 709 1415

**Malaysia:** No. 76 Jalan Universiti, 46200 PETALING JAYA, SELANGOR,  
Tel. +60 3 750 5214, Fax. +60 3 757 4880

**Mexico:** 5900 Gateway East, Suite 200, EL PASO, TEXAS 79905,  
Tel. +9-5 800 234 7381, Fax +9-5 800 943 0087

**Middle East:** see Italy

**Netherlands:** Postbus 90050, 5600 PB EINDHOVEN, Bldg. VB,  
Tel. +31 40 27 82785, Fax. +31 40 27 88399

**New Zealand:** 2 Wagener Place, C.P.O. Box 1041, AUCKLAND,  
Tel. +64 9 849 4160, Fax. +64 9 849 7811

**Norway:** Box 1, Manglerud 0612, OSLO,  
Tel. +47 22 74 8000, Fax. +47 22 74 8341

**Pakistan:** see Singapore

**Philippines:** Philips Semiconductors Philippines Inc.,  
106 Valero St. Salcedo Village, P.O. Box 2108 MCC, MAKATI,  
Metro MANILA, Tel. +63 2 816 6380, Fax. +63 2 817 3474

**Poland:** Al.Jerozolimskie 195 B, 02-222 WARSAW,  
Tel. +48 22 5710 000, Fax. +48 22 5710 001

**Portugal:** see Spain

**Romania:** see Italy

**Russia:** Philips Russia, Ul. Usatcheva 35A, 119048 MOSCOW,  
Tel. +7 095 755 6918, Fax. +7 095 755 6919

**Singapore:** Lorong 1, Toa Payoh, SINGAPORE 319762,  
Tel. +65 350 2538, Fax. +65 251 6500

**Slovakia:** see Austria

**Slovenia:** see Italy

**South Africa:** S.A. PHILIPS Pty Ltd., 195-215 Main Road Martindale,  
2092 JOHANNESBURG, P.O. Box 58088 Newville 2114,  
Tel. +27 11 471 5401, Fax. +27 11 471 5398

**South America:** Al. Vicente Pinzon, 173, 6th floor,  
04547-130 SÃO PAULO, SP, Brazil,  
Tel. +55 11 821 2333, Fax. +55 11 821 2382

**Spain:** Balmes 22, 08007 BARCELONA,  
Tel. +34 93 301 6312, Fax. +34 93 301 4107

**Sweden:** Kottbygatan 7, Akalla, S-16485 STOCKHOLM,  
Tel. +46 8 5985 2000, Fax. +46 8 5985 2745

**Switzerland:** Allmendstrasse 140, CH-8027 ZÜRICH,  
Tel. +41 1 488 2741 Fax. +41 1 488 3263

**Taiwan:** Philips Semiconductors, 5F, No. 96, Chien Kuo N. Rd., Sec. 1,  
TAIPEI, Taiwan Tel. +886 2 2134 2451, Fax. +886 2 2134 2874

**Thailand:** PHILIPS ELECTRONICS (THAILAND) Ltd.,  
60/14 MOO 11, Bangna Trad Road KM. 3, Bagna, BANGKOK 10260,  
Tel. +66 2 361 7910, Fax. +66 2 398 3447

**Turkey:** Yukari Dudullu, Org. San. Blg., 2.Cad. Nr. 28 81260 Umraniye,  
ISTANBUL, Tel. +90 216 522 1500, Fax. +90 216 522 1813

**Ukraine:** PHILIPS UKRAINE, 4 Patrice Lumumba str., Building B, Floor 7,  
252042 KIEV, Tel. +380 44 264 2776, Fax. +380 44 268 0461

**United Kingdom:** Philips Semiconductors Ltd., 276 Bath Road, Hayes,  
MIDDLESEX UB3 5BX, Tel. +44 208 730 5000, Fax. +44 208 754 8421

**United States:** 811 East Arques Avenue, SUNNYVALE, CA 94088-3409,  
Tel. +1 800 234 7381, Fax. +1 800 943 0087

**Uruguay:** see South America

**Vietnam:** see Singapore

**Yugoslavia:** PHILIPS, Trg N. Pasica 5/v, 11000 BEOGRAD,  
Tel. +381 11 3341 299, Fax.+381 11 3342 553

**For all other countries apply to:** Philips Semiconductors,  
Marketing Communications, Building BE-p, P.O. Box 218, 5600 MD EINDHOVEN,  
The Netherlands, Fax. +31 40 27 24825

**Internet:** <http://www.semiconductors.philips.com>

© Philips Electronics N.V. 2001

SCA 72

All rights are reserved. Reproduction in whole or in part is prohibited without the prior written consent of the copyright owner.

The information presented in this document does not form part of any quotation or contract, is believed to be accurate and reliable and may be changed without notice. No liability will be accepted by the publisher for any consequence of its use. Publication thereof does not convey nor imply any license under patent- or other industrial or intellectual property rights.

Printed in The Netherlands

753503/05/pp28

Date of release: 2001 Jun 29

Document order number: 9397 750 08498

*Let's make things better.*

**Philips  
Semiconductors**



**PHILIPS**